

# twilight

INSTRUMENTOS DE MEDICIÓN INDUSTRIAL

## Penetrómetro FR-5120, Capacidad 20.00 Kg, Lutron LT-FR5120

[www.twilight.mx](http://www.twilight.mx)

 / [twightsadecv](https://www.facebook.com/twightsadecv)

 / [twightsadecv](https://twitter.com/twightsadecv)

 / [twightsadecv](https://www.youtube.com/twightsadecv)

**20 Kg x 0.01 Kg ( 10 g )**

**Precision Fruit Sclerometer**

# **FRUIT HARDNESS TESTER**

**Model : FR-5120**



Your purchase of this FRUIT HARDNESS TESTER marks a step forward for you into the field of precision measurement. Although this METER is a complex and delicate instrument, its durable structure will allow many years of use if proper operating techniques are developed. Please read the following instructions carefully and always keep this manual within easy reach.

**OPERATION MANUAL**

# TABLE OF CONTENTS

1 FEATURES.....	1
2 SPECIFICATIONS.....	2
3 FRONT PANEL DESCRIPTIONS .....	4
3-1 Universal Sensing Head.....	4
3-2 LCD Display.....	4
3-3 Fast Indicator.....	4
3-4 FAST/SLOW Button.....	4
3-5 LCD Reverse Display Button.....	4
3-6 Zero Button.....	4
3-7 Kg/LB/Newton Unit.....	4
3-8 Power Off/On/Peak Hold.....	4
3-9 Mounting Holes/fixing Screws.....	4
3-10 Battery Cover/Compartment.....	4
3-11 11 mm Penetrometer Tip, FRTP-11.....	4
3-12 8 mm Penetrometer Tip, FRTP-8.....	4
3-13 5 mm Penetrometer Tip, FRTP-5.....	4
3-14 3 mm Penetrometer Tip, FRTP-3.....	4
3-15 LCD Back Light Button.....	4
3-16 DC 9V Power Adapter Input Socket.....	4
3-17 RS-232 output terminal.....	4
4 MEASURING PROCEDURE .....	5
4-1 Pay attentions for the measurement.....	5
4-2 Normal Measurement .....	6
4-3 Peak Hold Measurement .....	7
4-4 LCD Back light On/Off.....	7
5 BATTERY REPLACEMENT .....	8
6 RS232 PC SERIAL INTERFACE.....	8
7 MOUNTING HOLES & OPTIONAL TEST STAND.....	10

# 1. FEATURES

- \* The tester is used to measure the hardness of most kind fruits such as apple, pear, strawberry, grape, large/hard fruits, small/soft fruits. It is suitable for the fruit scientific research department, fruit company, fruit farm, agriculture colleges and universities to improve the fruit quality, the harvest storage, the product transportation... by the fruits' hardness. The useful tester to judge fruit's mature degree.
- \* Max. capacity : 20 Kgf x 0.01 Kgf ( 10 gf ).
- \* Unit : Kg/LB/Newton.
- \* Use load cell sensor, high precision.
- \* Digital display with Peak hold function, easy measurement.
- \* Tension or Compression, Zero.
- \* Positive/ Reverse display.
- \* Large LCD display with back light.
- \* Tip size : 3 mm, 5 mm, 8 mm, 11 mm.
- \* RS-232/USB computer interface.
- \* Complete set with hard carrying case and 4 kind tips ( 3 mm, 5 mm, 8 mm, 11 mm ).
- \* Test stand, FS-1001, optional.
- \* USB cable ( USB-01) and the data acquisition are optional.
- \* Peak hold ( Max. load ) can be held in display during make the measurement.
- \* Zero button can operate both for normal measuring & the " peak hold " operation.
- \* Full capacity zero (tare) control capability.
- \* Fast/Slow response time push button.
- \* Hand held & stand mounted gauges are available.
- \* Low power consumption gives long battery life.
- \* Microprocessor circuit & exclusive load cell transducer.
- \* Over load protection.
- \* Built-in DC 9V power adapter input socket.

## 2. SPECIFICATIONS

Principal	<p>The hardness of Fruit can express by the unit area ( S ) could undertake the pressure of dynamometer ( N ) , their specific value is just as the hardness ( P ).</p> $P = N / S$ <p><i>P = Hardness value of fruit ( Kg/cm<sup>2</sup> )</i>  <i>N = Pressure of dynamometer ( N, Kg, LB )</i>  <i>S = Area of pressure ( m<sup>2</sup>, cm<sup>2</sup> )</i></p>
Display	<p>LCD ( Liquid crystal display ).            5 digits, 16 mm ( 0.63" ) digit size.            Back light.</p>
Display Direction	<p>Positive or Reverse direction, select by the push button on the front panel.</p>
Function	<p>Tension &amp; Compression (Push &amp; Pull).            Normal force, Peak hold ( Max. load ).</p>
Peak hold	<p>Will freeze the display value of the Peak load ( Max. load ).</p>
Zero	<p>Zero button can be operated both for "normal force" or "peak hold" operation</p>
Unit select	<p>Kg/Newton/LB.</p>
Measure Capacity	<p>20.00 Kg/44.10 LB/196.10 Newton.</p>
Resolution	<p>0.01 Kg/0.01 LB/0.05Newton.</p>
Min. Display	<p>0.02 Kg/0.07 LB/0.3 Newton,</p>
Accuracy	<p>± (0.5 % + 2 digits), within 23± 5°C.            * Under the test weight on 10 Kg &amp; 20 Kg.</p>
Update time	<p>Fast Approx. 0.2 second.            Slow Approx. 0.6 second.</p>
Over range Indicator	<p>Display show " - - - - " when in over range status.</p>
Data output	<p>RS-232 serial computer interface.</p>

Overload Capacity	Max. 30 kg.
Full Scale Deflection	Approx. 0.4 mm max.
Zero/tare Control	Max. full capacity.
Circuit	Exclusive microprocessor LSI-circuit.
Power Supply	6 x 1.5 V AA (UM-3) size battery or DC 9V adapter (not included).
Power Consumption	Approx. DC 28 mA
Transducer	Exclusive load cell.
Operating Temperature	0°C to 50°C ( 32°F to 122°F ).
Operating Humidity	Less than 80% RH.
Dimension	215 x 90 x 45 mm ( 8.5 x 3.5 x 1.8 inch ).
Weight	650 g ( 1.43 LB )/with batteries.
Data output	RS-232 serial computer interface
Mounting Holes	Main instrument with mounting holes are provided on the back case, easy stand mounting.
Accessories Included	Operating manual ..... 1 PC. 11 mm Penetrometer Tip, FRTP-11..... 1 PC. 8 mm Penetrometer Tip, FRTP-8..... 1 PC. 5 mm Penetrometer Tip, FRTP-5..... 1 PC. 3 mm Penetrometer Tip, FRTP-3..... 1 PC. Carrying case ..... 1 PC.
Optional Accessories	* Test stand, Model : FS-1001 * RS232 cable, Model : UPCB-01. * USB cable, Model : USB-01. * SD card data recorder, DL-9602SD. * Software for data logging & data recorder, Model : SW-U801-WIN.

## 3. FRONT PANEL DESCRIPTION

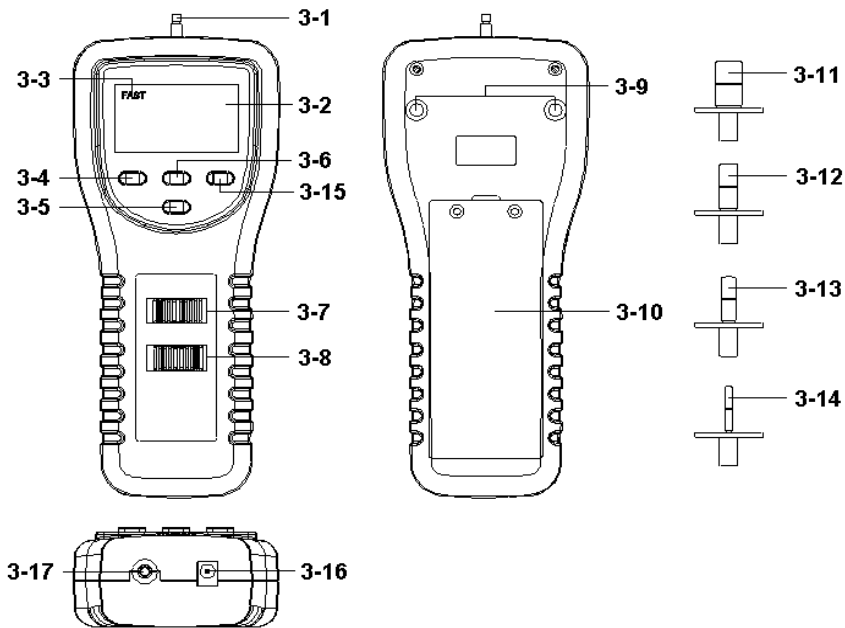

Fig. 1

- |   |  |
|---|--|
| 3-1 Universal Sensing Head                    | 3-10 Battery Cover/Compartment           |
| 3-2 LCD Display                               | 3-11 11 mm Penetrometer Tip ( F RTP-11 ) |
| 3-3 Fast Indicator                            | 3-12 8 mm Penetrometer Tip ( F RTP-8 )   |
| 3-4 FAST/SLOW Button                          | 3-13 5 mm Penetrometer Tip ( F RTP-5 )   |
| 3-5 LCD Reverse Display Button                | 3-14 3 mm Penetrometer Tip ( F RTP-3 )   |
| 3-6 Zero Button                               | 3-15 LCD Back Light Button               |
| 3-7 Kg/Newton/LB Unit Switch                  | 3-16 DC 9V Power Adapter Input Socket    |
| 3-8 Power Off/On/Peak Hold<br>0 = Off, 1 = On | 3-17 RS-232 output terminal              |
| 3-9 Mounting Holes/fixing Screws              |  |

## 4. MEASURING PROCEDURE

### 4-1 Pay attentions for the measurement

- 1) When make the fruit hardness testing, it always use compression function, the display will show the " " - " mark automatically.

*Remark :*

*The meter can use the " Tension " measurement, however for the fruit hardness measurement is not use this function typically.*

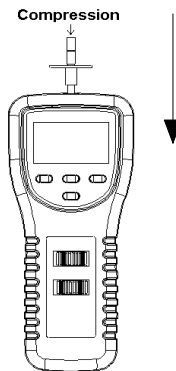

- 2) Pressure head and fruits should be vertical surface. When make the measurement, the Sensing Head along the tip should be on a line with measuring fruits ( ref. Fig. 2 )

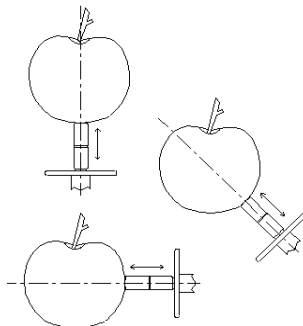

Fig. 2



- 3) Rotate the Sensing Head is prohibited. Some certain angles between Sensing Head & measuring object are not allowed ( ref. Fig. 3 ).

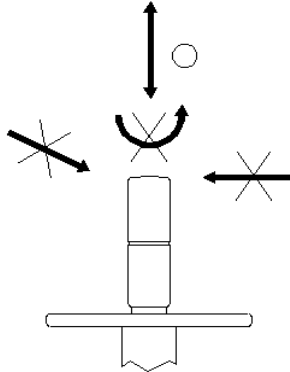

Fig. 3

#### **4-2 Normal Measurement**

- 1) Slide the " Power Off/On/Peak Hold Switch " ( 3-8, Fig. 1 ) to the " On " position.  
0 = Off, 1 = On
- 2) Determine display unit of g, oz or Newton by selecting " Kg/Newton/LB Unit Switch " ( 3-7, Fig. 1 ).
- 3) Connect " Sensing Head " ( 3-1, Fig. 1 ) with proper " Adapter " ( 3-11 to 3-14, Fig. 1 ) and the " Measuring Object " should be in straight line. Don't give any force in standby mode..
- 4) " Zero Adjust " by pushing " Zero Button " ( 3-6, Fig. 1 ) before every measurement.
- 5) Start measurement by giving force (push or pull), then the LCD will display the Average reading value.

*\* During the measurement, if intend to change the display direction, just push the " Reverse Button " ( 3-5, Fig. 1 ) once.*

- \* There are two kind sampling time of display, FAST and SLOW. Push the " FAST/SLOW Button " once ( 3-4, Fig. 1 ), if the upper left corner of LCD show " FAST " ( Fast Indicator, 3-3, Fig. 1 ), then the display reading is under the operation of fast sampling time.
- \* If the upper left corner of LCD not show the " Fast Indicator " ( 3-3, Fig. 1 ), the display reading is under the slow sampling time.
- \* Over range display of tension function, LCD will show " - - - - - "
- \* Over range display of compression function, LCD will show " - - - - - "

### ***4-3 Peak Hold Measurement***

The meter can measure the peak value of force both of tension & compression operation. The operation procedures of Peak Hold Measurement are same as above " 4-2 Normal Measurement " but should slide the " Power Off/On/Peak Hold Switch " ( 3-8, Fig. 1 ) to the " PEAK H. " position.

Slide the " Power Off/On/Peak Hold Switch " ( 3-8, Fig. 1 ) to the " On " position will cancel the peak hold function.

### ***4-4 LCD Back Light On/Off***

During the measurement, press and hold ( > 2 seconds ) the " \* Button " ( 3-15, Fig. 1 ) until LCD Back Light is ON, then it will be off after a period time. several seconds then off automatically

## 5. BATTERY REPLACEMENT

- 1) When the LCD shows " Lo ", it is necessary to replace the batteries. However, in-spec. measurement may still be made for several hours after low battery indicator appears before the instrument become inaccurate.
- 2) Take out the battery cover ( 3-10, Fig. 1 ) away from the instrument and remove the batteries.
- 3) Install the batteries ( 6 x 1.5 V AA, UM-3 ) correctly into the battery case.

## 6. RS232 PC SERIAL INTERFACE

The instrument features an RS232 output via 3.5 mm Terminal ( 3-17, Fig. 1 ).

The connector output is a 16 digit data stream which can be utilized to the user's specific application.

An RS232 lead with the following connection will be required to link the instrument with the PC serial input.

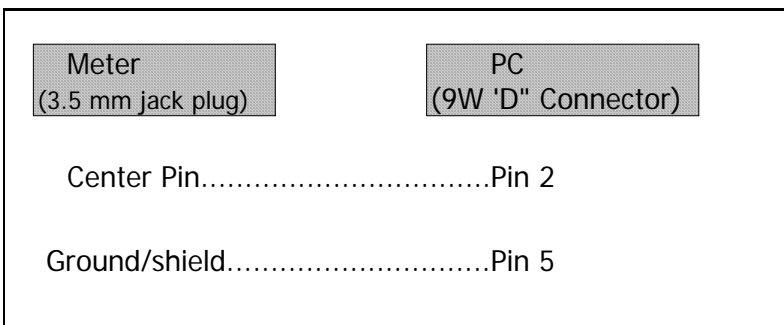

**The 16 digit data stream will be displayed in the following format :**

D15 D14 D13 D12 D11 D10 D9 D8 D7 D6 D5 D4 D3 D2 D1 D0
---

**Each digit indicate the following status :**

D0	End Word		
D1 & D8	Display reading, D1 = LSD, D8 = MSD <i>For example :</i> <i>If the display reading is 1234, then D8 to D1 is : 1234</i>		
D9	Decimal Point(DP), position from right to the left 0 = No DP, 1= 1 DP, 2 = 2 DP, 3 = 3 DP		
D10	Polarity 0 = Positive 1 = Negative		
D11 & D12	Anunciator for Display		
	g = 57	Newton = 59	oz =58
	Kg = 55	LB = 56	
D13	1		
D14	4		
D15	Start Word		

**RS232 setting**

Baud rate	9600
Parity	No parity
Data bit no.	8 Data bits
Stop bit	1 Stop bit

## 7. MOUNTING HOLES & OPTIONAL TEST STAND

Fruit hardness tester is a precise instrument, best results are obtained when the gauge is fitted to a test stand. Mounting holes ( 3-9, Fig. 1 ) are provided on the back of the gauge for easy stand mounting.

### Optional Test Stand & accessory :

\* TEST STAND, Model : FS-1001

Test stand, cooperate with Force gauge, whole system will be become the useful tool for material's tension & compression analysis.

Size : 630 x 250 x 230 mm. Weight : 7.02 Kg ( 15.4 LB ).



# twilight

INSTRUMENTOS DE MEDICIÓN INDUSTRIAL



LLÁMANOS

+52(81) 8115-1400 / +52 (81) 8173-4300

LADA Sin Costo:  
01 800 087 43 75

E-mail:  
[ventas@twilight.mx](mailto:ventas@twilight.mx)

[www.twilight.mx](http://www.twilight.mx)



/ [twightsadecv](https://www.facebook.com/twightsadecv)



/ [twightsadecv](https://twitter.com/twightsadecv)



/ [twightsadecv](https://www.youtube.com/twightsadecv)